

auto electrical parts

Technical Information Sheet

Part No . 0-525-22 (12v) 0-525-72 (24v)

12 or 24 volt battery condition marine voltmeter, 90° sweep dial. LED illumination, plastic cased with stainless steel bezel and screw collar type fitting.

Additional Information

Illumination white.



Technical Drawing (not to scale)

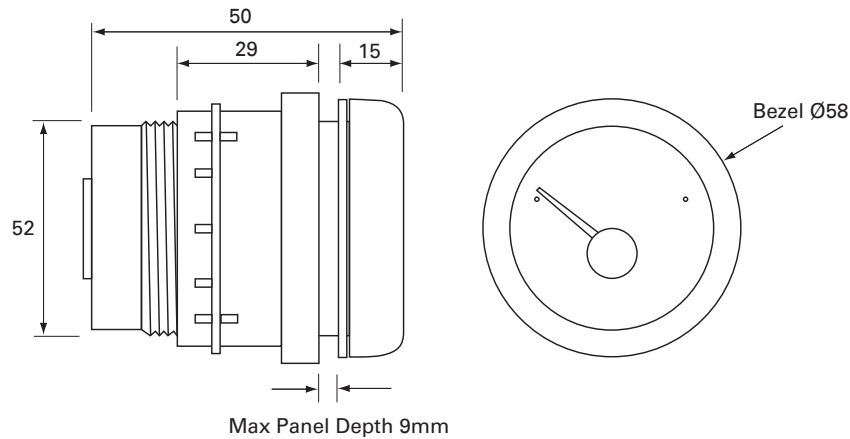

Specification

Type	Panel mount marine voltmeter
Voltage	12 or 24 volt DC
Scale	90° sweep, 8 - 16 volt or 16 - 32 volt
Illumination	LED white
Power Consumption	0.03A at 12VDC. 0.02A at 24VDC
Cable length	550mm
Panel Cut out	52mm
Max panel depth	9mm
Protection	IP65 (front)
Weight	130g
Dimensions	See diagram

The information contained in this document is correct to the best of our knowledge at the time of printing. However, specifications may change at any time without notice.